



MAKING YOUR DREAMS A REALITY

FITTING INSTRUCTIONS

HONDA MSX 125/GROM

Adjustable Step Kits: STAA-0019 and STAA-1019



MSX125 Grom Adjustable Step Kit

Fitting Instructions, MSX125 Grom Adjustable Step Kit STAA-0019, STAA-0019

Congratulations on your purchase of the TYGA Performance Step Kit. Please take a few minutes to familiarise yourself with the components and to read the fitting instructions below.

The step kit is delivered ready to bolt on in the #1 position (Highest rotation), and with the peg in the low position (as shown in drawing).

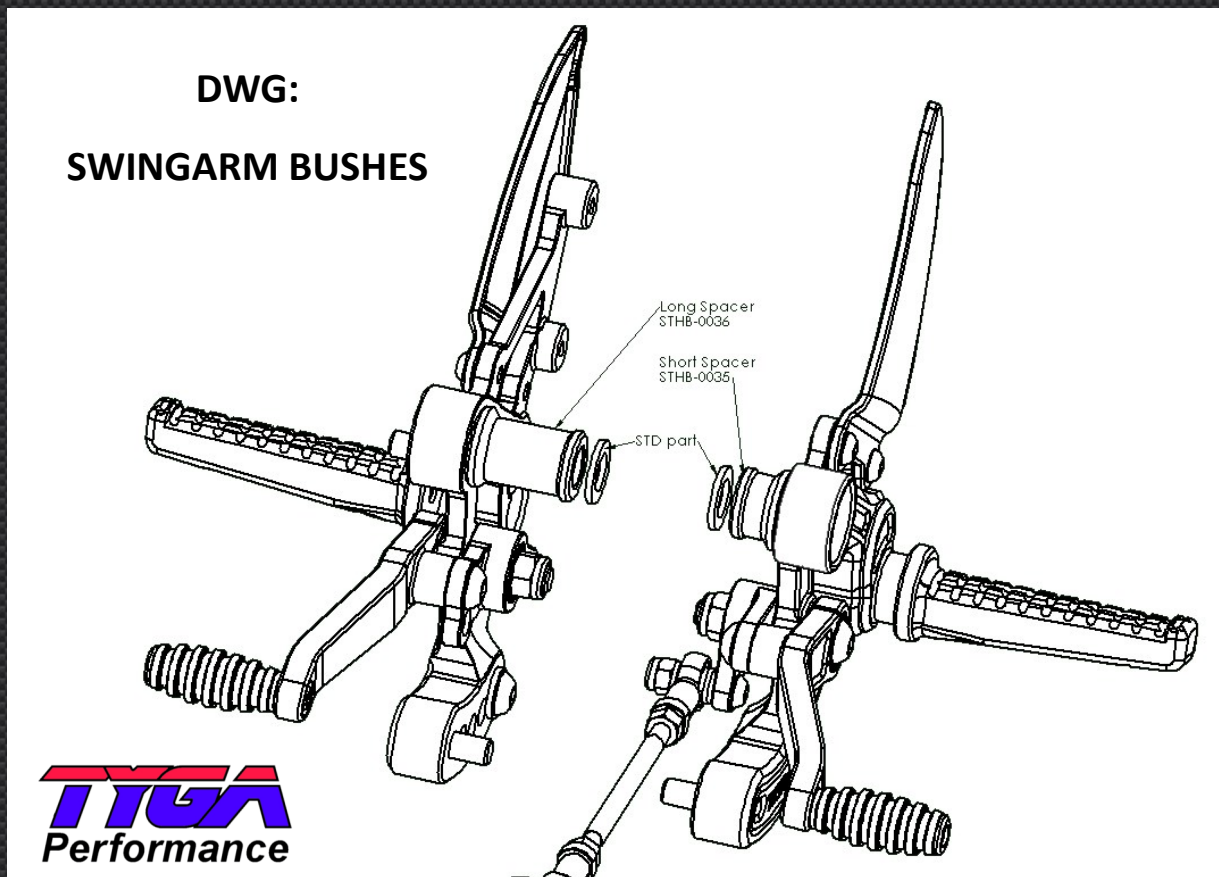

Make sure of the correct orientation of the swingarm bushes. The larger diameter side of the bush should be fitted up against hanger. Please refit the standard MSX125 washer between the bush and the swingarm bush/bearing. This standard Honda washer helps to spread load from bush/bearing, otherwise damage will be caused to the TYGA parts.

DWG:
AVAILABLE POSITIONS

TYGA
Performance

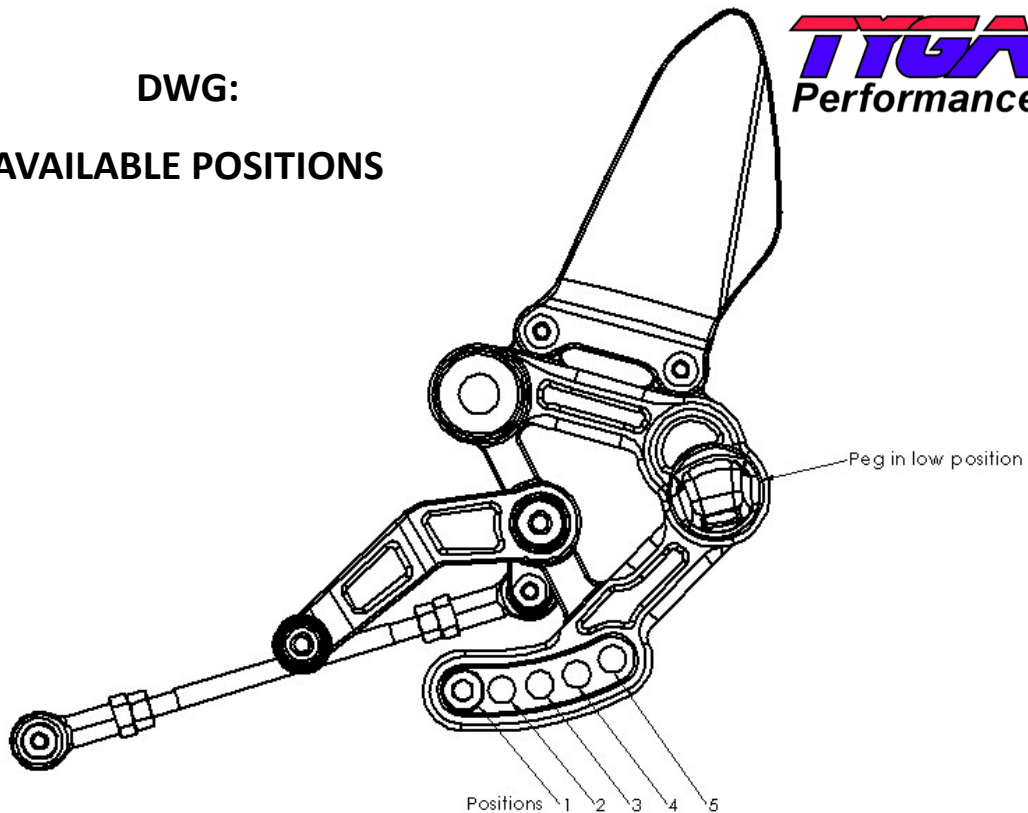

This drawing shows the available positions for the MSX125 Step Kit. The left side hanger is shown in the drawing, but the basic adjustment of the hanger is the same for both sides.

- The Swingarm axle must be loosened to perform adjustment.
- The lower M8x20 cap head bolt is accessed by removing the slot cover (with TYGA logo - not shown), and changed to new position.
- The step kit is rotated about the swingarm axle to 1 of 5 positions.
 - It is necessary to either remove the gear change arm from the gear selector shaft, or remove the bolt from the rod end attached to the gear change arm. This allows freedom of movement.

The link rod length is to be adjusted when the position is selected.

This will be explained later.

TYGA
Performance

DWG:
BRAKE LEVER
ADJUSTMENT

TTGA
Performance

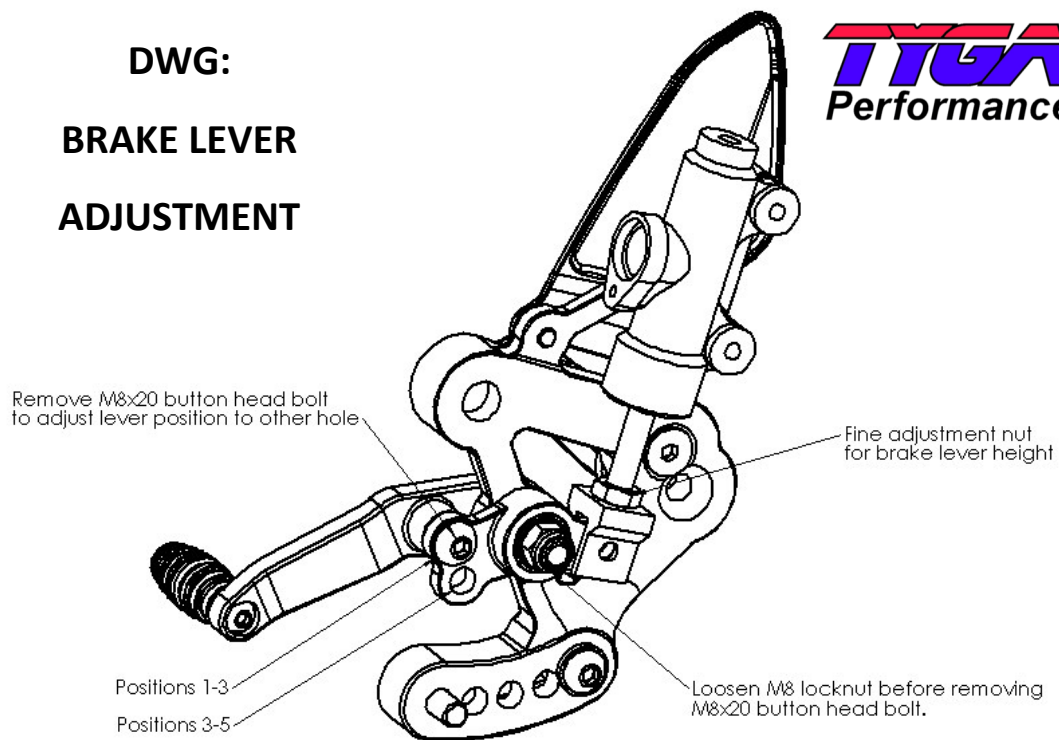

This drawing shows the lever set up for use in position 1-3. To adjust hanger to positions 3-5 the following adjustments are necessary.

- Loosen the M8 locknut on the brake lever pivot bearings. No need to remove.
- Remove M8x20 button head. Move lever to use other hole and refit M8x20 button head. Do not tighten yet.
- Tighten M8 locknut. This ensures pivot bearings are inline.
- Now tighten M8x20 button.
- Fine adjustments to lever height can be made by loosening the locknut on the brake master pushrod and adjusting up or down as required.



DWG:
GEAR LEVER
ADJUSTMENT

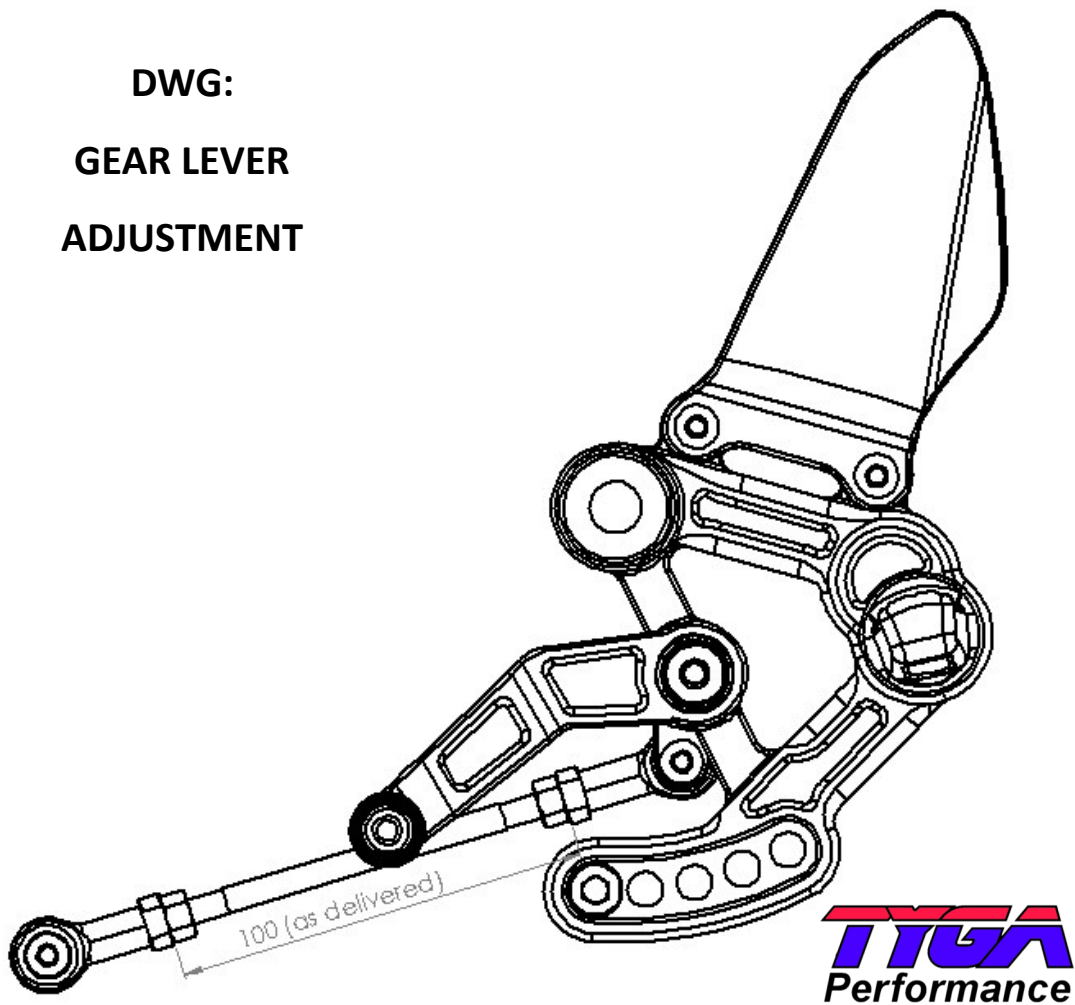

This drawing shows the lever set up for use in position 1. Pitch from rod end to rod end is 100mm.

- Adjusting the lever height for positions 1-3 is simply a case of adjusting the link rod length by loosening the 2x M6 locknuts and turning the rod to your preferred lever height.

- Tighten 2x M6 locknuts.

- For positions 3-5 it is necessary to move the change arm 1 spline from the standard position (in a Clockwise rotation). Then fine adjustment is done as above for each position.



DWG:
PEG ADJUSTMENT

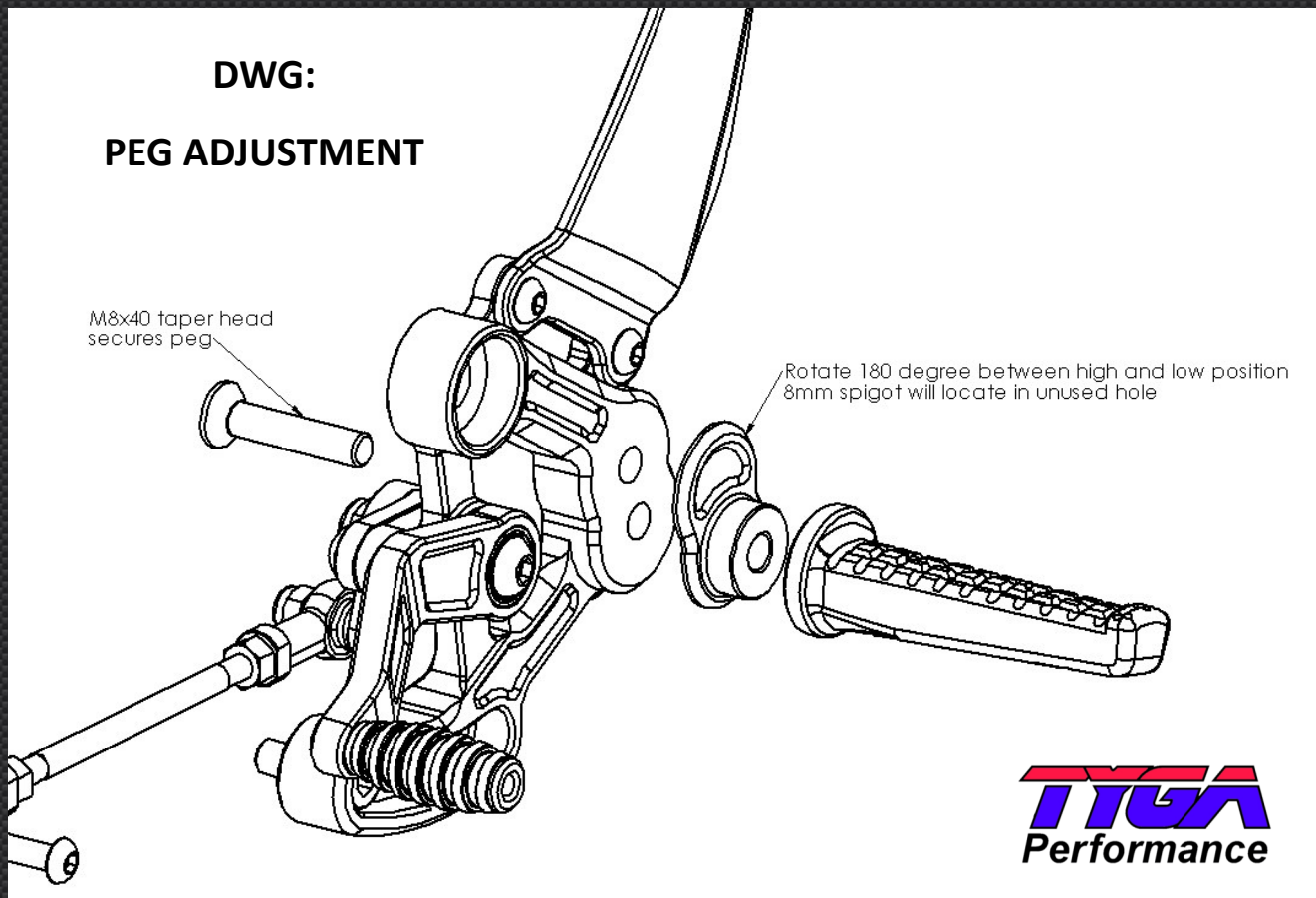

This drawing shows the peg in the low position. To change:

- Remove the M8x40 taper head bolt the peg and spacer will be free.
- Turn spacer through 180 degrees and relocate on hanger. The 8mm spigot on back of spacer assists location.
- Refit M8x40 taper head bolt.
- Orient the gripping part of peg to your preference and tighten in position.

NOTE

Position 3 will have some crossover for all the adjustment possibilities depending on your style/size, so suggest you play with it until you find the comfortable position.





All parts of this MSX125/GROM Step kit assembly are available as replacement parts which you will find [here](#)



www.tyga-performance.com